

THE  
FISHER



T. M. REG.

SERVICE AND  
MAINTENANCE  
NOTES

MODELS 60, 61, 65

COMPRISING:  
60-R TUNER  
60-A AMPLIFIER  
60-AP POWER SUPPLY

FISHER RADIO CORPORATION  
NEW YORK, N. Y.

## GENERAL INFORMATION

THE FISHER Custom Sixty has been designed for those desiring an FM-AM receiver of professional quality. It comprises a two-band superheterodyne circuit and employs completely independent RF and IF channels for AM and FM. There are three stages of IF and a ratio detector on FM, one stage of IF on AM and a tuned RF stage ahead of the first detector on both AM and FM. Automatic Frequency Control (AFC) is incorporated on FM to assure accurate tuning and complete freedom from drift. The Fisher Custom Sixty is supplied with built-in FM and AM antennas. Terminals are also provided for connection of external antennas, where the latter are desirable. The external FM antenna input is designed to operate either with 300-ohm balanced lead-in or 72-ohm coaxial shielded lead-in.

The sixty-watt audio amplifier employs push-pull parallel power output to assure extremely low distortion even at high power. The carefully designed flywheel tuning mechanism is unexcelled in simplicity and ease of station selection. The slide rule dial glass has large, easy-to-read numerals, edge lighted. There are individual channel indicator lights. Receptacles are available for instant connection of the FISHER Dynamic Range Expander. An auxiliary input receptacle is furnished for connection to the sound channel of a television receiver, microphone pre-amplifier, etc. The receiver is connected to this jack when the Channel Selector Switch is turned to the "TV" position. An AC receptacle mounted on the rear apron of the chassis supplies current for the operation of a Television Receiver when the Channel Selector Switch is turned to the "TV" position.

## OPERATING INSTRUCTIONS ANTENNAS

The built-in FM antenna is of the folded dipole type and is satisfactory in most urban locations. Where reception is desired either from weak or remote FM stations, we recommend the use of the specially matched, FISHER FM Antenna System.

The AM antenna consists of a loop mounted inside the speaker compartment. It is the only antenna required for reception of local broadcast stations, except where the receiver is used in unusually noisy locations or at a distance from broadcasting centers. In the event that an outside antenna is required, we recommend the use of THE FISHER Noise-Reducing Antenna System. This system offers optimum efficiency in bringing, from the roof to the receiver, the signal available in the location in which the receiver is to be used. CAUTION: NEVER disconnect the AM loop antenna plug, *whether or not the receiver is used with an external antenna.*

## ON-OFF SWITCH

The On-Off Switch and the Bass Tone Control are regulated by the same knob. When turning the set on continue the rotation of the knob to that point which gives the desired degree of bass intensity. For further details see "Bass Tone Control."

## TONE CONTROLS

**TREBLE TONE CONTROL.** This control can be used to regulate brilliance. For a more intimate tone, turn to left; for brighter tone, turn to right. Set it at the point you find most pleasing, for the particular program being played.

**BASS TONE CONTROL.** Should be set to minimum (extreme left) on male speaking voice. For music, according to personal taste. When playing music at low volumes, the usual loss in bass intensity (due to one's inherently reduced hearing efficiency at low volumes) can be compensated for by turning the control clockwise to the desired degree.

## THE FISHER DYNAMIC RANGE EXPANDER (Optional Equipment)

THE FISHER Dynamic Range Expander is designed to restore to records the full accents and crescendos of the original performance, usually monitored out of the recording at the time it was made, because of the limited dimensions of the groove. Turn the control to the right, to the desired degree. It will then operate automatically. The main volume control should be set at that point where, with the amount of expansion produced, the maximum volume will be within the desired limit. NOTE: If the Expander is purchased after the delivery of the original set, it can be instantly connected. Simply remove the jumper that will be found on the two receptacles marked "Expander" on the rear apron of the chassis. Connect the input of the Expander to the receptacle on the chassis marked "Expander Input"; connect the output of the Expander to the receptacle on the chassis marked "Expander Output."

## CHANNEL SELECTOR SWITCH

Turn Channel Selector knob to the desired channel whether Broadcast, FM, Phonograph, or Television Sound input. Lights on the dial scale indicate the channel to which the knob is set.

## AUTOMATIC FREQUENCY CONTROL ON FM

THE FISHER FM Receiver is equipped with an Automatic Frequency Control, designed to simplify tuning. You will find that when the dial pointer is brought within the vicinity of the desired channel, the station will automatically lock in and remain correctly tuned. It cannot drift out. The control regulating the range of lock-in is located on the rear apron of the chassis and is pre-set at our laboratories. In some locations, however, where a weak station is separated from a strong station by only two channels, the latter will tend to operate the control circuit and make it difficult to bring in the weak station. Should this occur, turn the Automatic Frequency Control (knurled brass shaft on the rear apron of the chassis) counter clockwise to the degree necessary to eliminate the above condition.

## ALIGNMENT PROCEDURE AM IF ALIGNMENT

NOTE: For the following IF and RF adjustments the signal generator should be readjusted as necessary to maintain the output below 2 volts across the voice coil.

1. With the Selector Switch in the Broadcast position, set the tuning capacitor for maximum capacity.
2. Feed a 455 Kc amplitude modulated signal to the signal grid of the 6BE6 converter tube (pin 7 of V-9) through a 0.1 mfd capacitor.
3. Set the Volume Control at maximum.
4. Connect an output meter across the speaker voice coil.
5. Adjust the top and bottom cores of the 1st and 2nd IF transformers (Z-5 and Z-6) for maximum. If noise causes excessive meter deflection, the Volume Control should be turned down slightly.

## BROADCAST ALIGNMENT

1. With the tuning capacitor completely closed, set the pointer to the index mark on the dial. (The first graduation mark appearing at the extreme left of the dial scale markings.)
2. Connect an amplitude modulated signal generator to the AM antenna terminals. A 200 mmfd capacitor should be inserted between the "high" side of the generator lead and the antenna terminal.

3. Set the dial and signal generator to 1400 Kc.
4. Adjust the Broadcast oscillator, RF and antenna coil trimmers (C-43, C-41 and C-36 respectively) for maximum.
5. Set the dial and signal generator to 600 Kc.
6. Adjust the Oscillator, RF and antenna coil cores (L-9, L-8 and L-7 respectively) for maximum.
7. Reset the dial and signal generator to 1400 Kc and repeat step 4 if necessary.

### FM DETECTOR ALIGNMENT

NOTE: For all of the following IF and RF adjustments the output of the signal generator should be readjusted as necessary to maintain the voltage at test point A (shown on schematic) between 8 and 9 volts dc.

1. Rotate the Selector Switch to the FM position.
2. Connect an electronic voltmeter between the chassis and the positive side of the 4 mfd electrolytic capacitor, C34. (Test point A on the schematic diagram.)
3. Feed an unmodulated 10.7 Mc signal through a .1 mfd capacitor to the 6BA6 FM detector-drive grid (pin 1 on V-6.)
4. Tune the FM detector primary (bottom of Z-4) for maximum.
5. Disconnect the electronic voltmeter from the 4 mfd capacitor and connect to the FM detector audio output (test point B on schematic diagram.)
6. Tune the FM detector secondary (top of Z-4) for zero.

### FM IF ALIGNMENT

1. Feed an unmodulated 10.7 Mc signal through a 500 to 1000 mmfd capacitor to the grid of the RF amplifier tube (pin 1 of V-1.)
2. Connect the electronic voltmeter to test point A as in step 2 above.
3. Align the top and bottom cores of the 1st, 2nd and 3rd IF coils (Z-1, Z-2 and Z-3 respectively) for maximum.

### FM RF ALIGNMENT

NOTE: For the following adjustments the AFC circuit should be disabled by turning the AFC control (R-13) fully counter-clockwise.

1. Set the dial to 106 Mc.
2. Feed a 106 Mc unmodulated signal to the 300-ohm FM antenna terminals with a 120 ohm composition resistor connected in series with each lead of the signal generator.
3. Connect the electronic voltmeter to test point A.
4. Adjust the oscillator, RF and antenna trimmers (C-12, C-7 and C-3 respectively) for maximum. For optimum adjustment rock the tuning capacitor back and forth while adjusting the RF trimmer.

### NOTE

THE FOLLOWING ADJUSTMENTS HAVE BEEN MADE AT THE FACTORY AND SELDOM REQUIRE REALIGNMENT EXCEPT WHEN COILS AND COMPONENTS IN THE FM RADIO-FREQUENCY SECTION HAVE BEEN REPLACED.

5. Set the signal generator to 90 Mc and tune the receiver for maximum as indicated on the electronic voltmeter.
6. If the dial calibration is off more than .2 Mc at 90 Mc, set the dial to 90 Mc and adjust the core in the FM oscillator coil (L-4) for maximum.
7. Adjust the core in the antenna coil (L-1) and spread or compress the RF coil (L-3) for maximum.
8. Reset the dial and signal generator to 106 Mc and repeat step 4.
9. Set the signal generator to 90 Mc and tune the receiver for maximum. If calibration has shifted as a result of step 8, repeat steps 6, 7 and 8.
10. If the receiver was badly out of alignment, step 9 may have to be repeated more than once.

### AUDIO AMPLIFIER ADJUSTMENTS BIAS ADJUSTMENT

1. Turn volume control fully counter clockwise.
2. Insert DC milliammeter between center tap (pin 2) of output transformer and high voltage supply (red wire).
3. Adjust the bias control (R-19) so that the plate current is exactly .135 amperes.

### HUM BALANCE ADJUSTMENT

1. Turn volume control fully counter clockwise.
2. Connect an audio vacuum tube voltmeter, such as Hewlett-Packard 400A, across the speaker jack.
3. Vary hum balance control (R-22) for minimum reading on output meter. Occasionally a distinct null point may not be found; in this event interchanging 6B4 tubes will cure this condition. In extreme cases it may be necessary to select 6B4 tubes.

### PHASE-INVERTER BALANCE ADJUSTMENT

This adjustment is only required when components in the phase-inverter circuit are replaced and should never be attempted unless a low distortion audio generator and either a wave analyzer or distortion analyzer are available.

1. Disconnect audio amplifier input from tuner chassis and feed the audio generator directly into the amplifier input (J1).
2. Disconnect the speaker and connect a 16 ohm 20 watt resistor across the 16 ohm amplifier output (pins 2 and 3 on jack J2.)
3. Connect wave analyzer or distortion analyzer across 16 ohm resistor.
4. Set the audio generator attenuator so that the amplifier produces 10 watts output (12.7 volts rms) across the 16 ohm resistor.
5. Tune the wave analyzer to the second harmonic of 1000 cps or if a distortion analyzer is used, tune it for minimum reading at 1000 cps.
6. Adjust the phase-inverter balance control for minimum distortion.

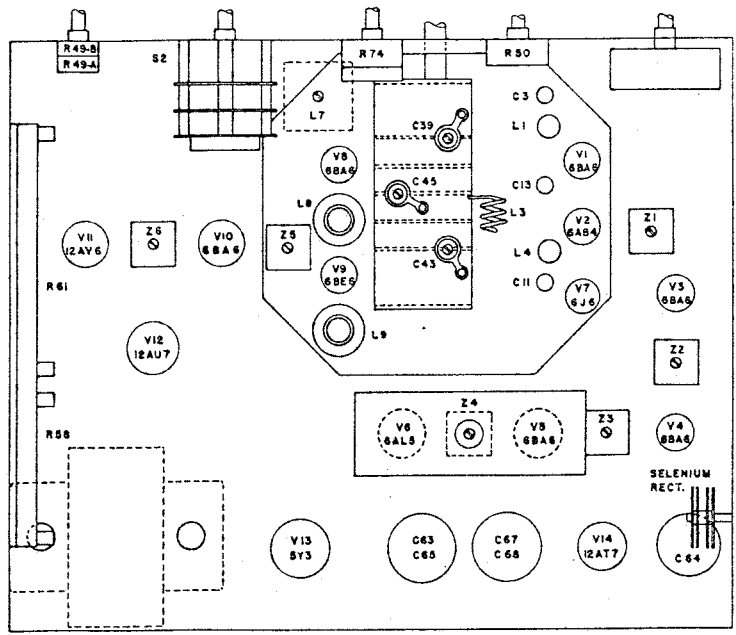
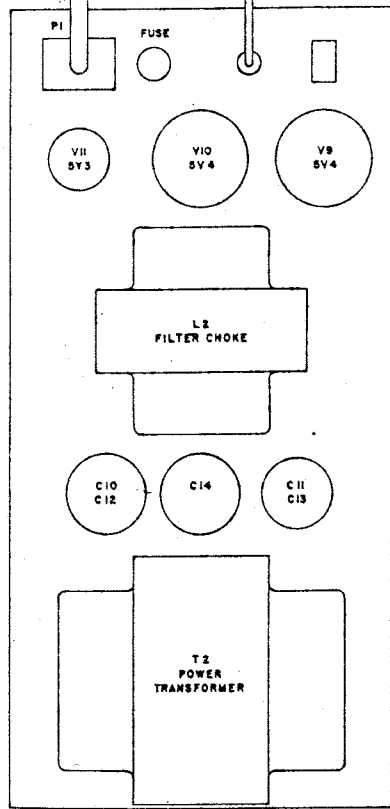
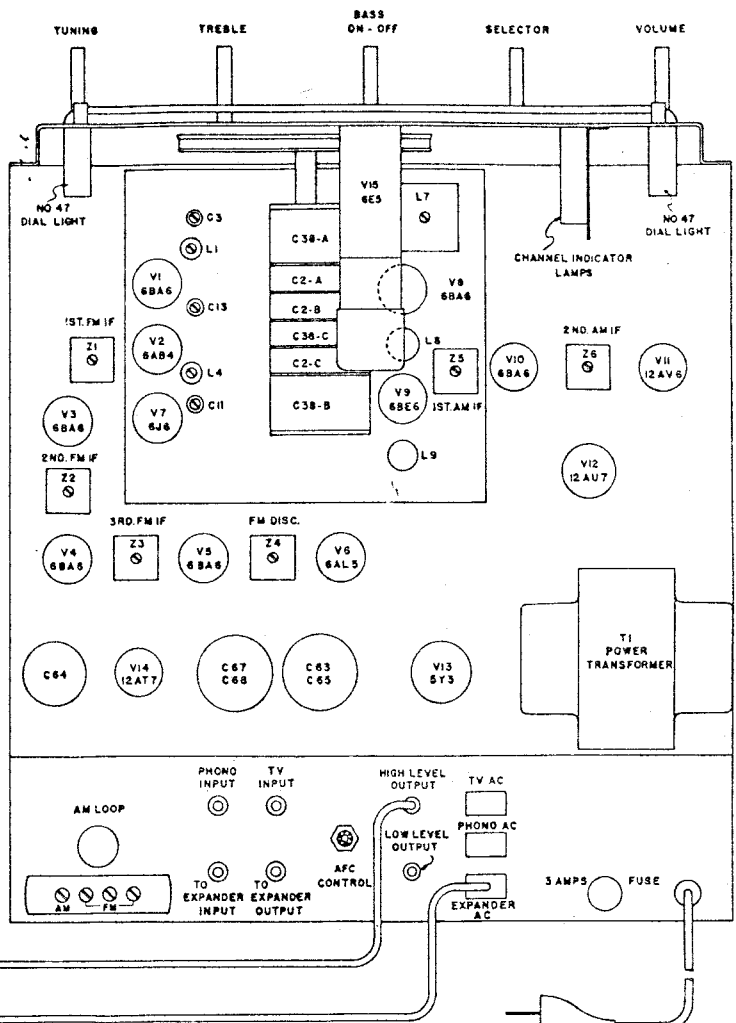
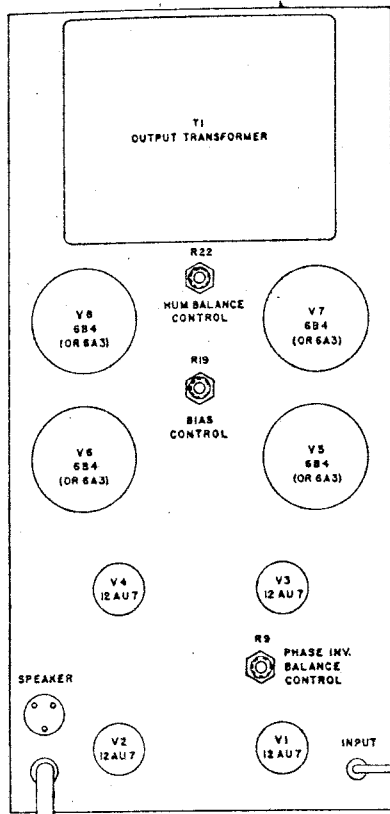

# LOCATION OF MAJOR COMPONENTS

## SPECIFICATIONS

**BAND**  
FREQUENCY MODULATION  
STANDARD BROADCAST

**TUNING RANGE**  
88 MC TO 108 MC  
540 KC TO 1600 KC

**INTERMEDIATE FREQUENCY**  
10.7 MC  
455 KC

**RADIO**: 105 TO 125 VOLTS AC 50/60 CYCLES 330 WATTS  
**PHONOGRAPH**: 105 TO 125 VOLTS AC 60 CYCLES 17 WATTS  
50 CYCLES AVAILABLE

## TUBE COMPLEMENT

TUNER			AMPLIFIER		
SYMBOL	TYPE	FUNCTION	SYMBOL	TYPE	FUNCTION
V1	6BA6	FM RF AMPLIFIER	V1	12AU7	AF AMPLIFIER, PHASE INVERTER
V2	6AB4	FM CONVERTER	V2	12AU7	PUSH-PULL AMPLIFIER
V3	6BA6	FM 1ST. IF AMPLIFIER	V3	12AU7	CATHODE COUPLED DRIVER
V4	6BA6	FM 2ND. IF AMPLIFIER	V4	12AU7	CATHODE COUPLED DRIVER
V5	6BA6	FM 3RD. IF AMPLIFIER	V5	6B4 (OR 6A3)	AUDIO POWER AMPLIFIER
V6	6AL5	FM DETECTOR	V6	6B4 (OR 6A3)	AUDIO POWER AMPLIFIER
V7	6J6	FM OSCILLATOR AND AFC	V7	6B4 (OR 6A3)	AUDIO POWER AMPLIFIER
V8	6BA6	AM RF AMPLIFIER	V8	6B4 (OR 6A3)	AUDIO POWER AMPLIFIER
V9	6BE6	AM OSCILLATOR AND CONVERTER			
V10	6BA6	AM IF AMPLIFIER			
V11	12AV6	AM DETECTOR & 1ST. AF AMPLIFIER			
V12	12AU7	CATHODE FOLLOWER OUTPUT			
V13	5Y3	FULL WAVE RECTIFIER			
V14	12AT7	PHONO PRE-AMPLIFIER			
V15	6E5	TUNING INDICATOR			

POWER SUPPLY		
SYMBOL	TYPE	FUNCTION
V9	5V4	FULL WAVE RECTIFIER
V10	5V4	FULL WAVE RECTIFIER
V11	5Y3	FULL WAVE RECTIFIER

102-E

# SPECIFICATIONS AND TUBE COMPLEMENT

### INSTRUCTIONS FOR REPLACEMENT OF DIAL CORD

1. REMOVE FOUR BAND INDICATOR LAMPS FROM BRACKET MOUNTED ON DIAL PLATE.
2. REMOVE DIAL LAMPS LOCATED AT EACH SIDE OF DIAL SCALE.
3. SLIDE TUNING EYE TUBE FREE OF CLIPS.
4. REMOVE THREE DIAL GLASS CLIPS (ONLY THOSE LABELED "A" IN ILLUSTRATION).
5. REMOVE DIAL PLATE BY UNSCREWING SIX HEXAGONAL SELF-TAPPING SCREWS (LABELED "B") HOLDING DIAL PLATE TO CHASSIS.
6. REMOVE OLD DIAL CORD AND RESTRING WITH NEW AS SHOWN IN ILLUSTRATION.
7. MOUNT DIAL PLATE ON CHASSIS.
8. RESTORE THE TUNING EYE TUBE, BAND INDICATOR LIGHTS AND DIAL LIGHTS.
9. REPLACE DIAL GLASS CLIPS. THE TWO UPPER CLIPS SHOULD ENCIrcLE THE DIAL CORD AND THE THIRD CLIP SHOULD ENCIrcLE THE WIRES TO THE DIAL LIGHT.
10. MOUNT DIAL POINTER AND WITH VARIABLE CAPACITOR FULLY CLOSED, CENTER POINTER OVER INDEX MARK ON DIAL.

#### NOTE:

USE ONLY DIAL CORD (PART NO. A1374) OBTAINABLE FROM FISHER RADIO CORPORATION.

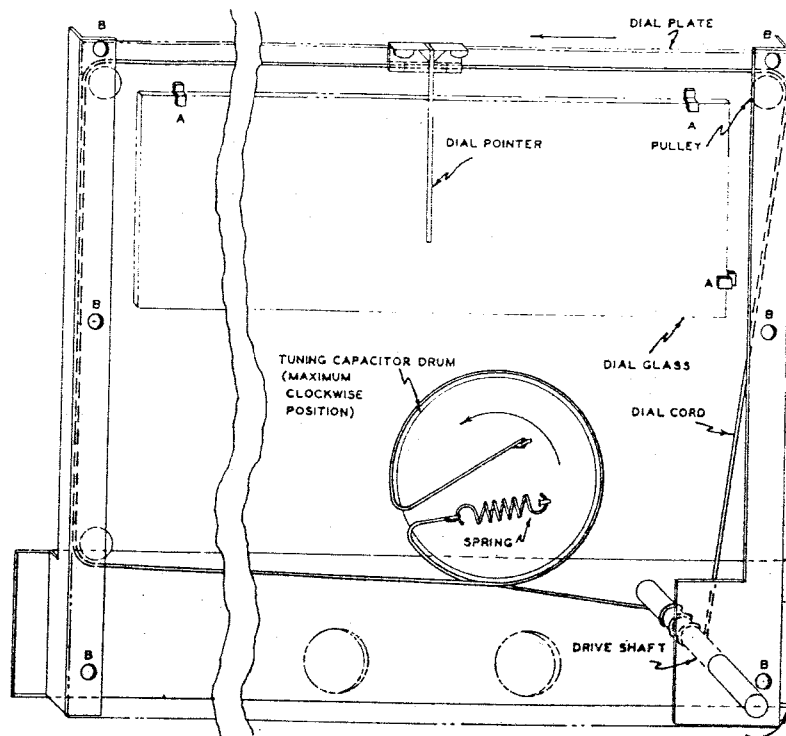

102-F

## DIAL STRINGING INSTRUCTIONS

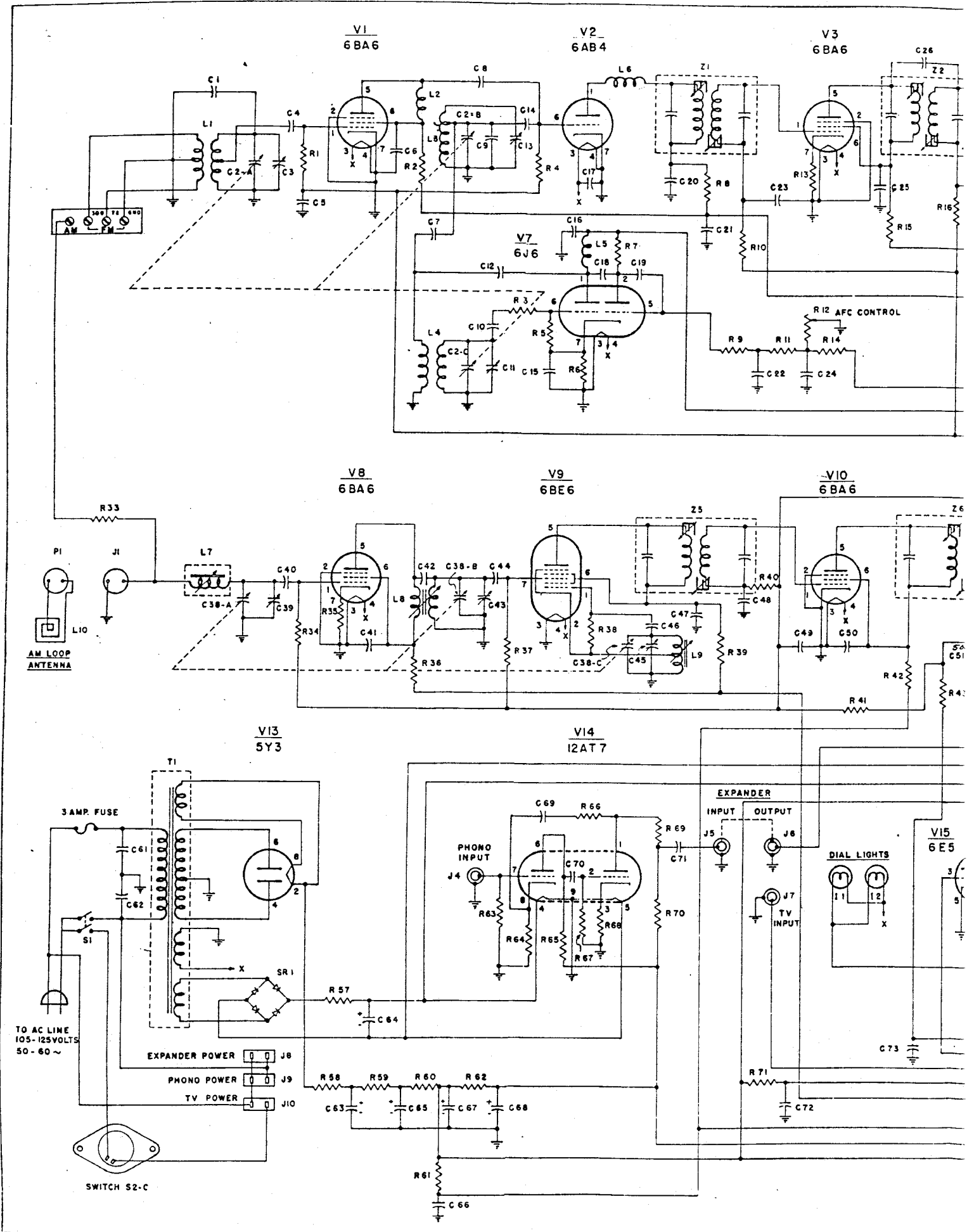

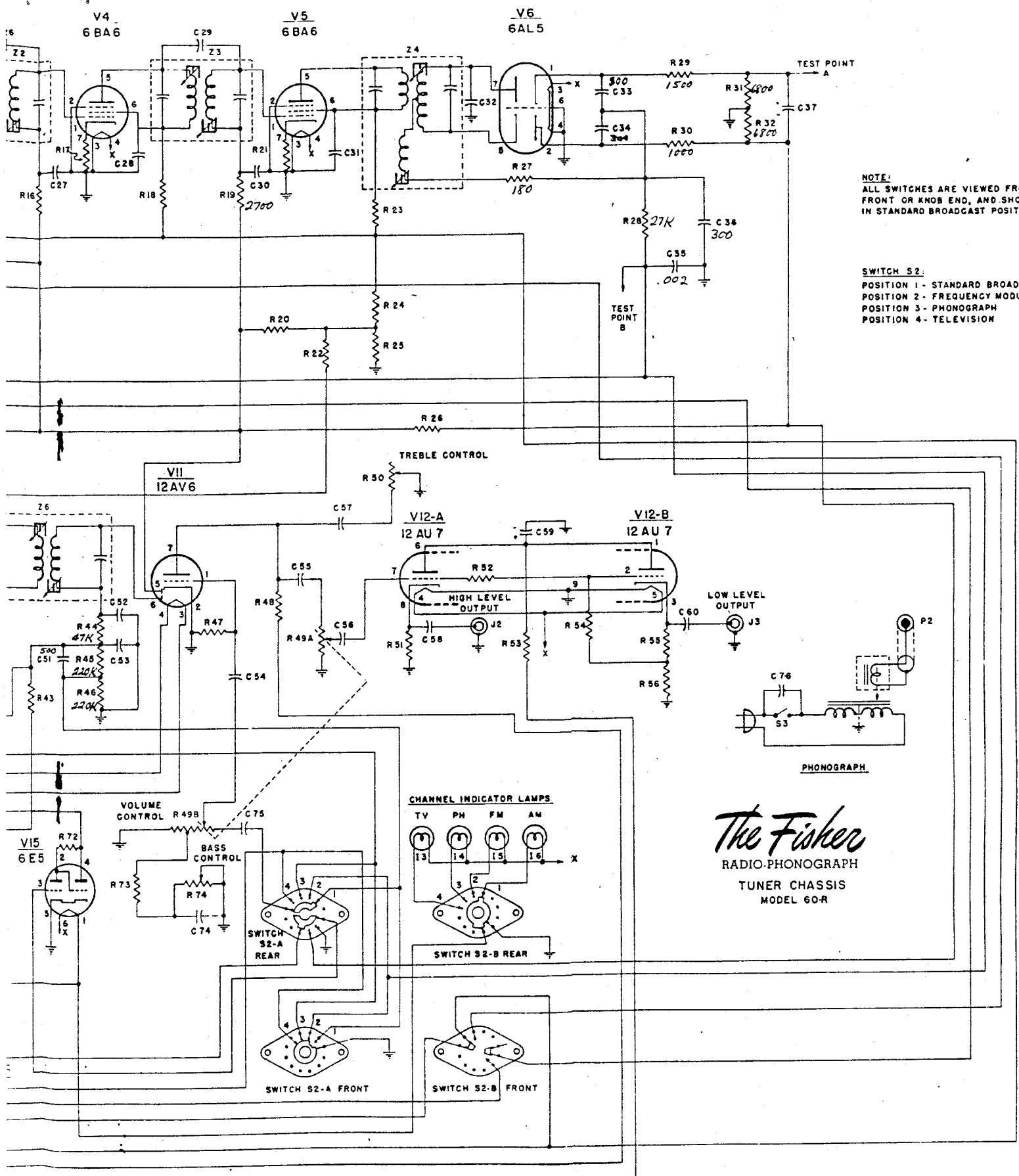

NOTE:  
 ALL SWITCHES ARE VIEWED FROM  
 FRONT OR KNOB END, AND SHOWN  
 IN STANDARD BROADCAST POSITION:

SWITCH S2:  
 POSITION 1 - STANDARD BROADCAST  
 POSITION 2 - FREQUENCY MODULAT  
 POSITION 3 - PHONOGRAPH  
 POSITION 4 - TELEVISION

*The Fisher*  
 RADIO-PHONOGRAPH  
 TUNER CHASSIS  
 MODEL 60-R

# AMPLIFIER

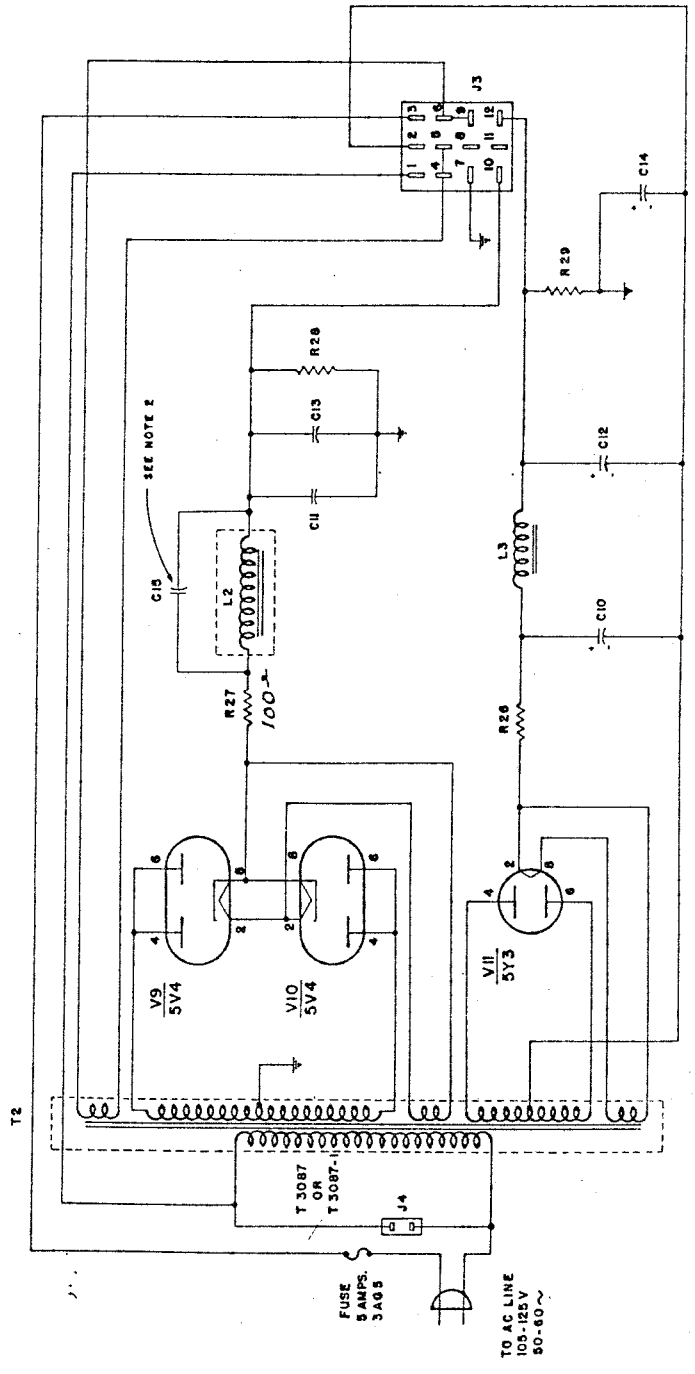
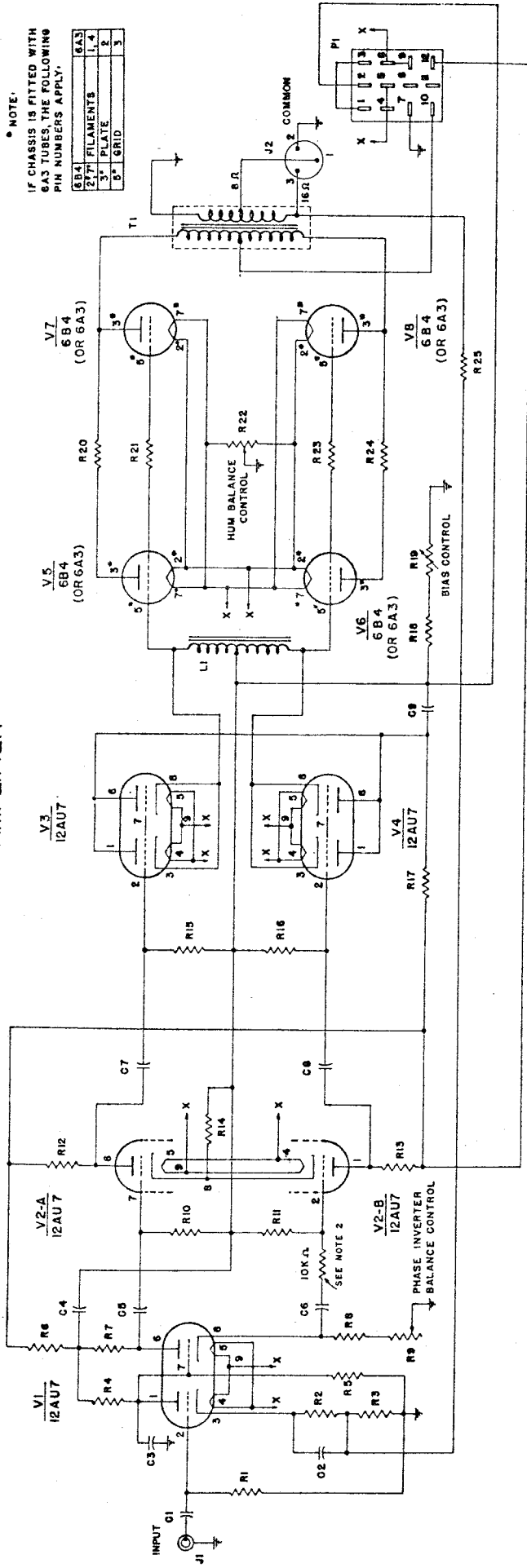

**NOTES:**  
1. WHEN SUPPLIED WITH POWER TRANSFORMER T3087-1, R27 IS OMITTED & R28 IS 20KΩ-20W  
2. PRESENT IN SOME MODELS

*The Fisher*  
RADIO-PHONOGRAPH  
AMPLIFIER MODEL 60A  
POWER SUPPLY MODEL 60AP

# POWER SUPPLY



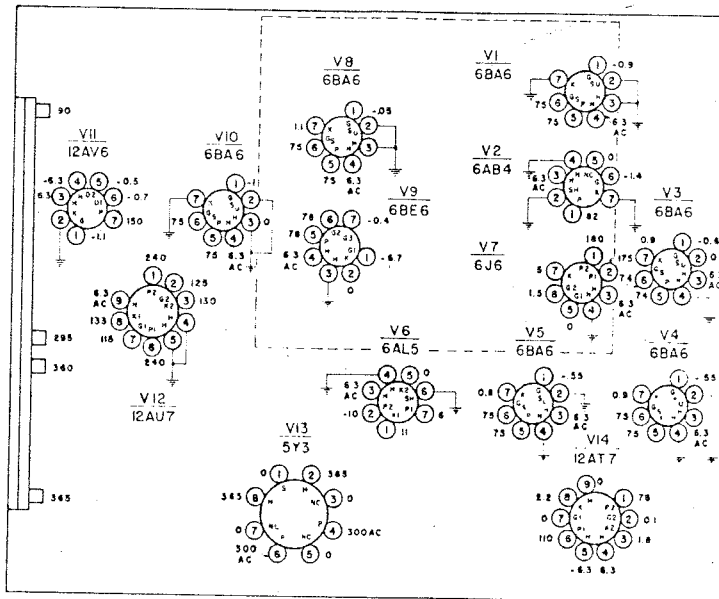

TUNER

NOTES

1. ALL VOLTAGES ARE TO BE MEASURED WITH AN ELECTRONIC VOLTMETER
2. ALL VOLTAGE READINGS ARE D.C. TO CHASSIS UNLESS OTHERWISE SPECIFIED
3. LINE VOLTAGE 117 VOLTS 60 CYCLES
4. BANDSWITCH S1 TO BE IN BROADCAST POSITION WITH DIAL SET AT 1000 KC FOR ALL TUBES EXCEPT V1, V2, AND V7 WHICH ARE MEASURED WITH BANDSWITCH IN F.M. POSITION
5. VOLUME CONTROL TO BE SET IN EXTREME COUNTER-CLOCKWISE POSITION

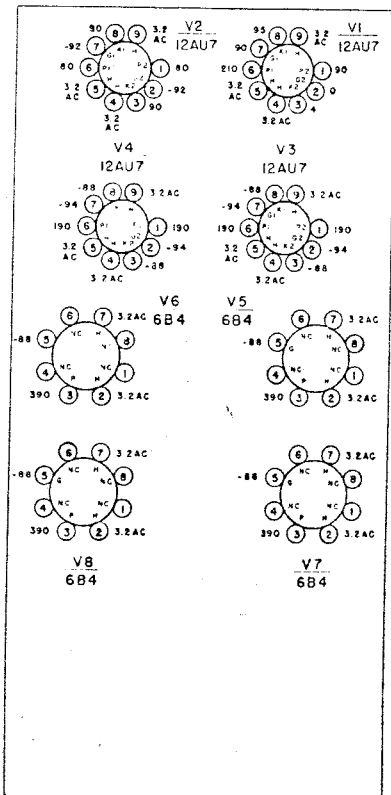

AMPLIFIER

NOTE:  
IF CHASSIS IS FITTED WITH  
6A3 TUBES, USE THIS CHART

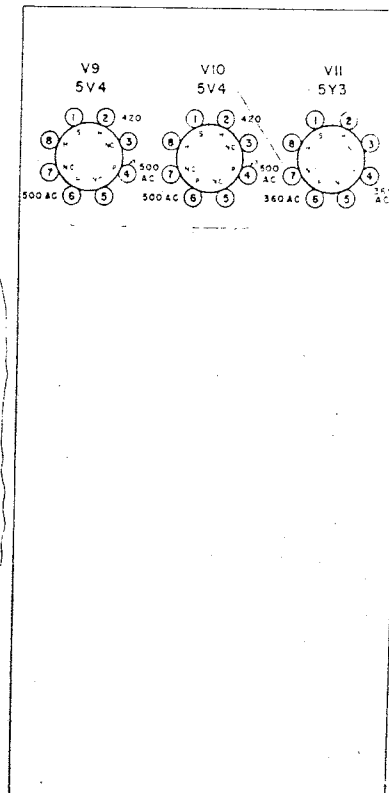
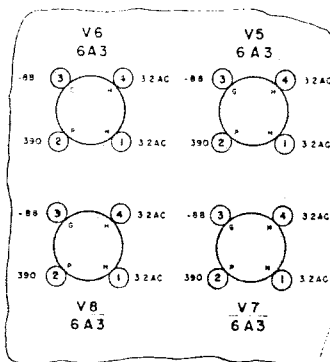

POWER SUPPLY

VOLTAGE REFERENCE CHART

# PARTS DESCRIPTION LIST

## TUNER CHASSIS, MODEL 60-R

Symbol	DESCRIPTION	Part No.	Symbol	DESCRIPTION	Part No.
C1	Capacitor, Ceramic: 10 mmfd; NPO	C-1317	C64	Capacitor, Electrolytic: 500 mfd; 15 V	C-3073
C2a, b, c	Capacitor, Variable: FM Section	C-2965	C65	Capacitor, Electrolytic: 40 mfd; 450 V	C-1798
C3	Capacitor, Trimmer: 1 - 8 mmfd	C-2970	C66	Capacitor, Molded Tubular: .1 mfd; 400 V	C-1102
C4	Capacitor, Ceramic: 500 mmfd	C-1315	C67	Capacitor, Electrolytic: 40 mfd; 450 V	C-1798
C5	Capacitor, Ceramic: .005 mfd	C-2146	C68	Capacitor, Electrolytic: 40 mfd; 450 V	C-1798
C6	Capacitor, Ceramic: .005 mfd	C-2146	C69	Capacitor, Mica: .003 mfd; 300 V	C-1219
C7	Capacitor, Ceramic: 2.2 mmfd	C-3039	C70	Capacitor, Paper Tubular: .002 mfd; 600 V	C-1990
C8	Capacitor, Ceramic: 4.7 mmfd	C-1779	C71	Capacitor, Molded Tubular: .1 mfd; 400 V	C-1102
C9	Capacitor, Ceramic: 2.2 mmfd	C-3039	C72	Capacitor, Molded Tubular: .1 mfd; 400 V	C-1102
C10	Capacitor, Ceramic: 47 mmfd; NPO	C-2147	C73	Capacitor, Molded Tubular: .022 mfd; 400 V	C-2946
C11	Capacitor, Trimmer: 1 - 8 mmfd	C-2970	C74	Capacitor, Molded Tubular: .022 mfd; 400 V	C-2946
C12	Capacitor, Ceramic: 500 mmfd	C-1315	C75	Capacitor, Molded Tubular: .1 mfd; 400 V	C-1102
C13	Capacitor, Trimmer: 1 - 8 mmfd	C-2970	C76	Capacitor, Molded Tubular: .01 mfd; 400 V	C-1109
C14	Capacitor, Ceramic: 1500 mmfd	C-1314	R1	Resistor, Composition: 470,000 ohms; ½ W	R-1836
C15	Capacitor, Ceramic: .005 mfd	C-2146	R2	Resistor, Composition: 1000 ohms; ½ W	R-1577
C16	Capacitor, Ceramic: .005 mfd	C-2146	R3	Resistor, Composition: 10 ohms; ½ W	R-1807
C17	Capacitor, Ceramic: .005 mfd	C-2146	R4	Resistor, Composition: 1 megohm; ½ W	R-1732
C18	Capacitor, Ceramic: 24 mmfd; NPO	C-1781	R5	Resistor, Composition: 22,000 ohms; ½ W	R-1736
C19	Capacitor, Ceramic: 10 mmfd; NPO	C-1317	R6	Resistor, Composition: 330 ohms; ½ W	R-1790
C20	Capacitor, Ceramic: .005 mfd	C-2146	R7	Resistor, Composition: 3300 ohms; 1 W	R-2415
C21	Capacitor, Ceramic: .005 mfd	C-2146	R8	Resistor, Composition: 2700 ohms; ½ W	R-1738
C22	Capacitor, Mica: 100 mmfd; 500 V	C-1318	R9	Resistor, Composition: 220 ohms; ½ W	R-1733
C23	Capacitor, Ceramic: .005 mfd	C-2146	R10	Resistor, Composition: 2700 ohms; ½ W	R-1738
C24	Capacitor, Molded Tubular: .047 mfd; 400 V	C-2944	R11	Resistor, Composition: 100,000 ohms; ½ W	R-1583
C25	Capacitor, Ceramic: .005 mfd	C-2146	R12	Potentiometer, Composition: 2.5 megohms	R-2403
C26	Capacitor, Ceramic: 1 mmfd	C-1786	R13	Resistor, Composition: 100 ohms; ½ W	R-2408
C27	Capacitor, Ceramic: .005 mfd	C-2146	R14	Resistor, Composition: 470,000 ohms; ½ W	R-1836
C28	Capacitor, Ceramic: .005 mfd	C-2146	R15	Resistor, Composition: 1000 ohms; ½ W	R-1577
C29	Capacitor, Ceramic: 1 mmfd	C-1786	R16	Resistor, Composition: 2700 ohms; ½ W	R-1738
C30	Capacitor, Ceramic: .005 mfd	C-2146	R17	Resistor, Composition: 100 ohms; ½ W	R-2408
C31	Capacitor, Ceramic: .005 mfd	C-2146	R18	Resistor, Composition: 1000 ohms; ½ W	R-1577
C32	Capacitor, Ceramic: 1 mmfd	C-1786	R19	Resistor, Composition: 2700 ohms; ½ W	R-1738
C33	Capacitor, Mica: 300 mmfd; 500 V	C-1789	R20	Resistor, Composition: 6.8 megohms; ½ W	R-2431
C34	Capacitor, Mica: 300 mmfd; 500 V	C-1789	R21	Resistor, Composition: 100 ohms; ½ W	R-2408
C35	Capacitor, Mica: .002 mfd; 500 V	C-1265	R22	Resistor, Composition: 18 megohms; ½ W	R-3009
C36	Capacitor, Mica: 300 mmfd; 500 V	C-1789	R23	Resistor, Composition: 1000 ohms; ½ W	R-1577
C37	Capacitor, Electrolytic: 4 mfd; 250 V	C-1886	R24	Resistor, Composition: 4700 ohms; 1 W	R-2418
C38a, b, c	Capacitor, Variable: AM Section	C-2965	R25	Resistor, Composition: 4700 ohms; 1 W	R-2418
C39	Capacitor, Trimmer	Part of C-2965	R26	Resistor, Composition: 2.2 megohms; ½ W	R-1734
C40	Capacitor, Mica: 300 mmfd; 500 V	C-1789	R27	Resistor, Composition: 180 ohms; ½ W	R-1782
C41	Capacitor, Molded Tubular: .01 mfd; 400 V	C-1109	R28	Resistor, Composition: 27,000 ohms; ½ W	R-2171
C42	Capacitor, Ceramic: 1 mmfd	C-1786	R29	Resistor, Composition: 1500 ohms; ½ W	R-1741
C43	Capacitor, Trimmer	Part of C-2965	R30	Resistor, Composition: 1000 ohms; ½ W	R-1577
C44	Capacitor, Mica: 300 mmfd; 500 V	C-1789	R31	Resistor, Composition: 6800 ohms; ½ W	R-1973
C45	Capacitor, Trimmer	Part of C-2965	R32	Resistor, Composition: 6800 ohms; ½ W	R-1973
C46	Capacitor, Mica: 300 mmfd; 500 V	C-1789	R33	Resistor, Composition: 1000 ohms; ½ W	R-1577
C47	Capacitor, Molded Tubular: .022 mfd; 400 V	C-2946	R34	Resistor, Composition: 1 megohm; ½ W	R-1732
C48	Capacitor, Molded Tubular: .022 mfd; 400 V	C-2946	R35	Resistor, Composition: 120 ohms; ½ W	R-1330
C49	Capacitor, Molded Tubular: .047 mfd; 400 V	C-2944	R36	Resistor, Composition: 1000 ohms; ½ W	R-1577
C50	Capacitor, Ceramic: .005 mfd	C-2146	R37	Resistor, Composition: 470,000 ohms; ½ W	R-1836
C51	Capacitor, Ceramic: 500 mmfd	C-1315	R38	Resistor, Composition: 22,000 ohms; ½ W	R-1736
C52	Capacitor, Mica: 100 mmfd; 500 V	C-1318	R39	Resistor, Composition: 1000 ohms; ½ W	R-1577
C53	Capacitor, Mica: 100 mmfd; 500 V	C-1318	R40	Resistor, Composition: 1 megohm; ½ W	R-1732
C54	Capacitor, Molded Tubular: .022 mfd; 400 V	C-2946	R41	Resistor, Composition: 2.2 megohms; ½ W	R-1734
C55	Capacitor, Molded Tubular: .047 mfd; 400 V	C-2944	R42	Resistor, Composition: 1000 ohms; ½ W	R-1577
C56	Capacitor, Molded Tubular: .022 mfd; 400 V	C-2946	R43	Resistor, Composition: 2.2 megohms; ½ W	R-1734
C57	Capacitor, Molded Tubular: .01 mfd; 400 V	C-1109	R44	Resistor, Composition: 47,000 ohms; ½ W	R-1580
C58	Capacitor, Molded Tubular: .1 mfd; 400 V	C-1102	R45	Resistor, Composition: 220,000 ohms; ½ W	R-1624
C59	Capacitor, Electrolytic: 20 mfd; 450 V	C-3132	R46	Resistor, Composition: 220,000 ohms; ½ W	R-1624
C60	Capacitor, Molded Tubular: .1 mfd; 400 V	C-1102	R47	Resistor, Composition: 18 megohms; ½ W	R-3009
C61	Capacitor, Molded Tubular: .01 mfd; 400 V	C-1109	R48	Resistor, Composition: 47,000 ohms; ½ W	R-1580
C62	Capacitor, Molded Tubular: .01 mfd; 400 V	C-1109	R49a	Potentiometer, Composition: 500,000 ohms	M-161
C63	Capacitor, Electrolytic: 40 mfd; 450 V	C-1798	R49b	Potentiometer, Composition: 500,000 ohms	M-162

# PARTS DESCRIPTION LIST

Symbol	DESCRIPTION	Part No.
R50	Potentiometer, Composition: 1 megohm	R-2815-2
R51	Resistor, Composition: 47,000 ohms; 1/2 W	R-1580
R52	Resistor, Composition: 1 megohm; 1/2 W	R-1732
R53	Resistor, Composition: 10,000 ohms; 1/2 W	R-1531
R54	Resistor, Composition: 39,000 ohms; 1/2 W	R-1938
R55	Resistor, Composition: 1500 ohms; 1/2 W	R-1741
R56	Resistor, Composition: 47,000 ohms; 1/2 W	R-1580
R57	Resistor, Wirewound: 5 ohms; 10 W	R-2732
R58, R61	Resistor, Wirewound: 50 ohms; 10 W and 3500 ohms; 15 W	R-2967
R59	Resistor, Wirewound: 500 ohms; 10 W	R-1841
R60	Resistor, Wirewound: 500 ohms; 10 W	R-1841
R62	Resistor, Composition: 22,000 ohms; 1/2 W	R-1736
R63	Resistor, Composition: 1 megohm; 1/2 W	R-1732
R64	Resistor, Composition: 2200 ohms; 1/2 W	R-1737
R65	Resistor, Composition: 100,000 ohms; 1/2 W	R-1583
R66	Resistor, Composition: 120,000 ohms; 1/2 W	R-2212
R67	Resistor, Composition: 2.2 megohms; 1/2 W	R-1734
R68	Resistor, Composition: 1000 ohms; 1/2 W	R-1577
R69	Resistor, Composition: 47,000 ohms; 1/2 W	R-1580
R70	Resistor, Composition: 22,000 ohms; 1/2 W	R-1736
R71	Resistor, Wirewound: 7000 ohms; 5 W	R-2241
R72	Resistor, Composition: 1 megohm; 1/2 W	R-1732
R73	Resistor, Composition: 10,000 ohms; 1/2 W	R-1531
R74	Potentiometer, Composition: 250,000 ohms	R-2815-3
I1	Lamp, Dial	I-2148
I2	Lamp, Dial	I-2148
I3	Lamp, Dial	I-2148
I4	Lamp, Dial	I-2148
I5	Lamp, Dial	I-2148
I6	Lamp, Dial	I-2148
J1	Jack: 2 Female Contacts	J-2070
J2	Jack, Phono: 1 Female Contact	J-1030
J3	Jack, Phono: 1 Female Contact	J-1030
J4	Jack, Phono: 1 Female Contact	J-1030
J5	Jack, Phono: 1 Female Contact	J-1030
J6	Jack, Phono: 1 Female Contact	J-1030
J7	Jack, Phono: 1 Female Contact	J-1030
J8	Jack, Line: 2 Female Contacts	J-1152
J9	Jack, Line: 2 Female Contacts	J-1152
J10	Jack, Line: 2 Female Contacts	J-1152
L1	Coil: FM Antenna	L-3041
L2	Choke: RF	L-1600
L3	Coil: FM RF	L-3042
L4	Coil: FM Oscillator	L-3043
L5	Choke: RF	L-1600
L6	Coil: Peaking	L-3011
L7	Coil: Loop Loading	L-2966
L8	Coil: BC RF	L-2960
L9	Coil: BC Oscillator	L-2961
L10	Loop: AM Antenna	LA-3004
P1	Plug: 2 Male Contacts	P-2072
P2	Plug: 1 Male Contact	P-1031
S1	Switch: AC Line	Part of R-2815-
S2	Switch: Band Selector	S-2958
T1	Transformer: Power	T-3096
Z1	Transformer: FM IF	ZZ-2988
Z2	Transformer: FM IF	ZZ-2987
Z3	Transformer: FM IF	ZZ-2987
Z4	Transformer: FM Detector	ZZ-2986
Z5	Transformer: AM IF	ZZ-2985
Z6	Transformer: AM IF	ZZ-2984

## AMPLIFIER, MODEL 60-A POWER SUPPLY, MODEL 60-AP

Symbol	DESCRIPTION	Part No.
C1	Capacitor, Molded Tubular: .1 mfd; 400 V	C-1102
C2	Capacitor, Electrolytic: 100 mfd; 6 V	C-1022
C3	Capacitor, Mica: 510 mmfd; 500 V	C-1791
C4	Capacitor, Electrolytic: 40 mfd; 450 V	C-1798
C5	Capacitor, Molded Tubular: .047 mfd; 400 V	C-2944
C6	Capacitor, Molded Tubular: .047 mfd; 400 V	C-2944
C7	Capacitor, Molded Tubular: .1 mfd; 400 V	C-1102
C8	Capacitor, Molded Tubular: .1 mfd; 400 V	C-1102
C9	Capacitor, Electrolytic: 40 mfd; 450 V	C-1798
C10	Capacitor, Electrolytic: 40 mfd; 450 V	C-1798
C11	Capacitor, Electrolytic: 40 mfd; 450 V	C-1798
C12	Capacitor, Electrolytic: 40 mfd; 450 V	C-1798
C13	Capacitor, Electrolytic: 40 mfd; 450 V	C-1798
C14	Capacitor, Electrolytic: 150 mfd; 200 V	C-3137
R1	Resistor, Composition: 1 megohm; 1/2 W	R-1732
R2	Resistor, Composition: 2200 ohms; 1/2 W	R-1737
R3	Resistor, Composition: 27 ohms; 1/2 W	R-3124
R4	Resistor, Composition: 100,000 ohms; 1/2 W	R-1583
R5	Resistor, Composition: 470,000 ohms; 1/2 W	R-1836
R6	Resistor, Composition: 2200 ohms; 1/2 W	R-1737
R7	Resistor, Composition: 47,000 ohms; 1/2 W	R-1580
R8	Resistor, Composition: 39,000 ohms; 1/2 W	R-1938
R9	Potentiometer, Composition: 25,000 ohms	R-3108
R10	Resistor, Composition: 1 megohm; 1/2 W	R-1732
R11	Resistor, Composition: 1 megohm; 1/2 W	R-1732
R12	Resistor, Composition: 100,000 ohms; 1/2 W	R-1583
R13	Resistor, Composition: 100,000 ohms; 1/2 W	R-1583
R14	Resistor, Composition: 2200 ohms; 1/2 W	R-1737
R15	Resistor, Composition: 470,000 ohms; 1/2 W	R-1836
R16	Resistor, Composition: 470,000 ohms; 1/2 W	R-1836
R17	Resistor, Wirewound: 3500 ohms; 5 W	R-3090
R18	Resistor, Wirewound: 3500 ohms; 5 W	R-3090
R19	Potentiometer, Wirewound: 1500 ohms	R-2399
R20	Resistor, Composition: 100 ohms; 1/2 W	R-2408
R21	Resistor, Composition: 10 ohms; 1/2 W	R-1807
R22	Potentiometer, Wirewound: 50 ohms	R-2399
R23	Resistor, Composition: 10 ohms; 1/2 W	R-1807
R24	Resistor, Composition: 100 ohms; 1/2 W	R-2408
R25	Resistor, Composition: 470 ohms; 1/2 W	R-1740
R26	Resistor, Wirewound: 50 ohms; 5 W	R-3093
R27	Resistor, Wirewound: 100 ohms; 10 W	R-3119
R28	Resistor, Wirewound: 20,000 ohms; 20 W or 10,000 ohms; 20 W (see note on amplifier schematic)	R-3112
R29	Resistor, Wirewound: 15,000 ohms; 10 W	<del>R-1112</del> R-1175
J1	Jack, Phono: 1 Female Contact	J-1030
J2	Jack: 3 Female Contacts	J-1589
J3	Jack: 12 Female Contacts	J-1255
J4	Jack, Line: 2 Female Contacts	J-1152
L1	Choke, Audio	L-3086
L2	Choke, Swinging	L-3083
L3	Choke, Filter	L-3084
P1	Plug: 12 Male Contacts	P-1256
T1	Transformer: Output	T-3088
T2	Transformer: Power	T-3087 or T-3087-1